

E-Lume-A-Path™ Emergency Egress Path Marking System Product Bulletin

Illuminated by FLATLITE® Electroluminescent Lamps, 'the world's widest, thinnest, longest lightbulb'™.

The E-Lume-A-Path™ (ELAP) Egress Path Marking System is a low level path marking and lighting system that provides a floor level, uninterrupted lighted path to safety while highlighting the doors of the appropriate emergency exits. The E-Lume-A-Path Egress Path Marking System is activated by input signals from fire alarm or other emergency systems. The system automatically activates in the event of a power failure with battery back up maintaining the system operation for over 4 hours at full load.

SYSTEM OVERVIEW

The E-Lume-A-Path™ System (ELAP) consists of a system controller, ¼" FLATLITE® electroluminescent light strip, and the ClearTrak nonmetallic lamp fixture system. The strip of lamp is then connected to the controller using distribution wiring. The controller is connected to the existing building power grid and to the fire alarm system through standard signal interface. In addition, the system can include optional low level EXIT signs along the path of travel and at designated exit doors.

These components combine to create a highly flexible system designed for ease of installation in new construction or retrofit installations:

E-Lume-A-Path™ SYSTEM COMPONENTS

- ▶ Model EP1500 System Controller
- ▶ Up to 1500 linear feet (450 Meters) of FLATLITE ¼ inch wide strip
- ▶ Lamp connectors with leads
- ▶ ClearTrak clear nonmetallic linear lamp fixture system
- ▶ WhiteTrak white nonmetallic linear lamp fixture system (optional)
- ▶ Wiremold® 400 blank end fittings and junction boxes.
- ▶ Low Level EXIT sign(s) (optional)
- ▶ Distribution wiring: The E-Lume-A-Path System is classified as a Class 1 Power Limited System per NFPA 70, National Electric Code (NEC) Section 725. Two conductor, 18 AWG stranded wire is recommended for lamp distribution.

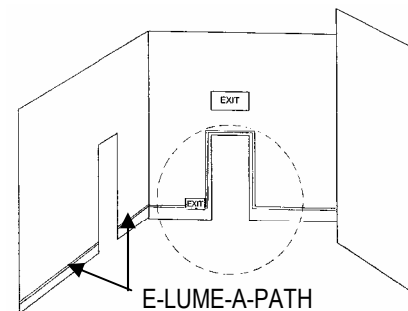

SYSTEM LISTING

The E-Lume-A-Path™ Egress Path Marking System is listed to Underwriters Laboratories Standard 1994 for Floor Proximity Path Marking Systems. The Low Level Exit Signs also meet UL's Standard 924 for Emergency Lighting and Power Equipment when used with the EP1500 controller.



MODEL EP1500 CONTROLLER RATINGS

Line Input Power: 100-270 VAC, 50/60Hz, Normal standby load – 5 watts; Active load – 125 watts at maximum load.

System Activation Control Signal Options: ▶ Contact Closure (load of 12vdc at 20ma) ▶ +10-24vdc (at 6-12ma load)
▶ Contact Opening (load of 12vdc at 20ma) ▶ Loss of line power

Controller Output: Nominal 210VAC at 600Hz, Power limited circuit with a maximum ampacity of less than 1.5 amps at full load of 1500 Linear Feet / 4500 square inches of FLATLITE lamp.

EGRESS MARKING SYSTEMS LLC
2285 RESERVOIR AVENUE
TRUMBULL, CT 06611-4743

PHONE: 203.610.6240
FAX: 203.610.6647
EMAIL: SALES@EGRESSMARKING.COM

The E-Lume-A-Path™ Lighting System is manufactured in the USA under US Patents 6,896,388 and 6,788,000

EMS
EGRESS MARKING SYSTEMS

SYSTEM OPERATION

In normal system operation, the E-Lume-A-Path™ Egress Path Marking System is not illuminated, but is in a ready state. It is activated either by a power outage or by sensing any one of the emergency signals it is connected to. If the system is activated by a power outage, the system will stay lit for a minimum of 4 hours utilizing the battery back-up system. Once the batteries are completely discharged, the system will continue to operate for a period of time in a flashing mode.

OUTPUT CHANNELS / MODES OF OPERATION:

The total rated system load can be carried on one or more of 4 output circuits, called channels that can be set to utilize any of the available functions. Each output channel has a 4-position dip switch used to set the channel functions which are summarized as follows:

- **Emergency Signal (Master Signal):** Responds to fire alarm or other building emergency signal. (Position 1 on the dip switch)
- **Loss of Line Signal:** Responds to loss of building AC line electrical power. (Position 2 on the dip switch)
- **Flashing Mode:** Can be used instead of Switch 1 (Emergency Signal). It will respond to fire alarm or other building emergency signal by flashing for approximately 2 minutes and then continue to stay on without flashing. The flash rate is approximately 2 times per second. The only difference between Flashing Mode and Emergency Signal is that the Flashing Mode does not respond to a Slave Input Signal. (Position 3 on the dip switch)
- **Dimming Mode:** This mode is for non-emergency convenience use such as control of aisle lighting or in wayfinding applications. When the dimming function is used, the brightness of the FLATLITE® lamps can be varied from completely off to standard brightness. The control for this brightness is external to the system controller, and will usually originate from some control point in the building. The control signal is a voltage 0 and 10 volts DC, with 10 volts representing the standard brilliance for the lamps. (Position 4 on the dip switch)

SYSTEM ACTIVATION

- **Emergency Signal (Master) Input:** This is the input signal from the building fire/emergency alarm system to the System Controller to notify it that there is an emergency. The Emergency Signal wires are connected to the System Controller during the installation of the controller and then terminated to the channel board. The unit can be made addressable by the fire alarm system by adding the fire alarm manufacturer's standard addressable module, for which a mounting location has been made available on the controller's channel board.
- **Loss Of Line Input:** The System Controller will switch to the battery back-up mode any time AC power is removed. Any channel set to respond to loss of line would light and the system would be capable of also responding to an emergency signal input.
- **Slave Signal Input:** The System Controller has the ability to send signals to or receive signals from other System Controllers. When this function is used, two wires from the Slave Out terminals of this unit are connected to the Slave In terminals of up to four other Model EP1500 System Controllers. the Slave In terminals are located at the bottom of the Channel Board.

BATTERY BACKUP / STANDBY POWER:

The EP1500 controller has an integral battery charger and battery set that is sized to fully run the system for a minimum of 4 hours. The battery backup is automatically engaged upon a loss of Line Power until the AC line power is restored or the backup battery becomes discharged. Additional backup time is achieved with the addition of battery capacity either within the controller or as a separate battery cabinet. The Battery system operates at 24 VDC and utilizes (2) 18 aH, 12VDC batteries that are charged in parallel through a 1-step charging process. Charge recovery time is < 24 hours.

PERIODIC SYSTEM TESTING

In accordance with standard practice for testing emergency lighting equipment, it is recommended that the E-Lume-A-Path Egress Path Marking System be functionally tested at 30 day intervals for not less than 30 seconds. It is additionally recommended that the system be functionally tested annually for not less than 90 minutes, because it has a battery back-up system.

EP 1500 System Controller – Figures and Diagrams

EP 1500 System Controller - Inside View

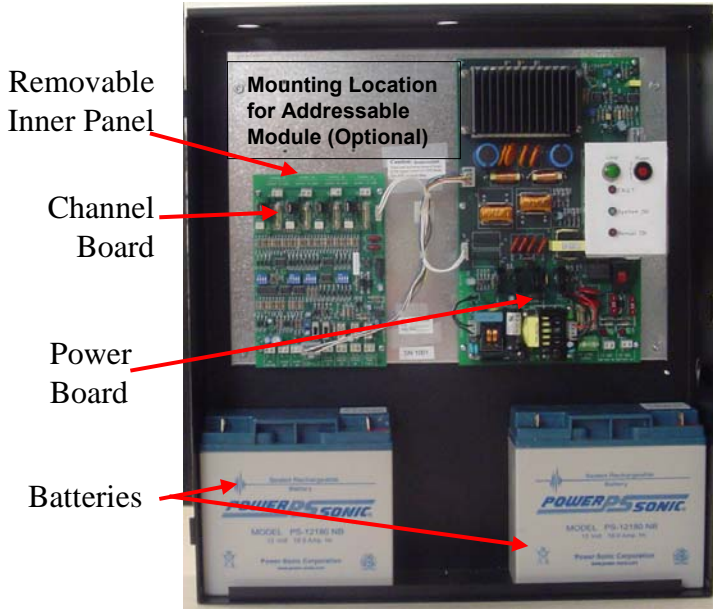

Channel Board Detail (Not To Scale)

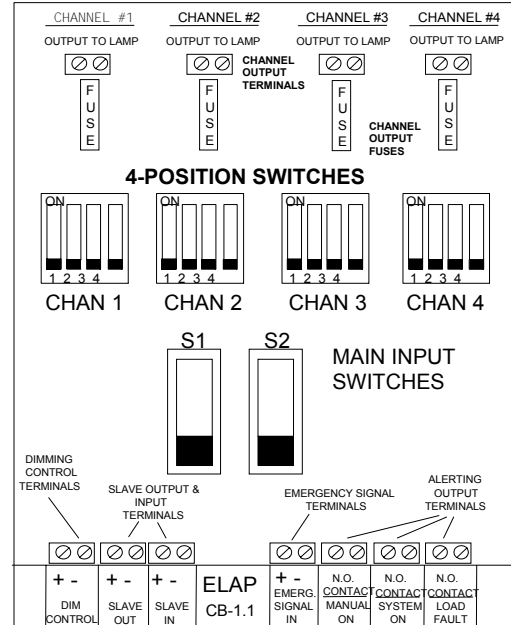

SYSTEM CAPACITY

The EP 1500 System Controller drives up to 4500 square inches of **FLATLITE®** Lamp, which includes both 1/4 inch strip and low level EXIT signs. Each lineal foot of 1/4 inch strip is 3 square inches in area of active lamp and each EXIT sign is 69 square inches in area of active lamp. When laying out a system it is important to keep in mind how many EXIT signs and how many linear feet of 1/4" strip will be allocated for each system controller. The reference chart shows how many linear feet of 1/4" strip can be powered for a given system controller based on the number of exit signs assigned to that controller. Note: If no EXIT signs are assigned to a given system controller, then a maximum of 1500 linear feet of 1/4" strip can be powered by that controller.

Reference Chart: Number of linear feet of 1/4" lamp strip that can be powered vs. the number of exit signs assigned to a given system controller

# of EXIT Signs	Linear Feet of 1/4" Lamp Available	# of EXIT Signs	Linear Feet of 1/4" Lamp Available	# of EXIT Signs	Linear Feet of 1/4" Lamp Available	# of EXIT Signs	Linear Feet of 1/4" Lamp Available
0	1500	17	1109	33	741	50	350
1	1477	18	1086	34	718	51	327
2	1454	19	1063	35	695	52	304
3	1431	20	1040	36	672	53	281
4	1408	21	1017	37	649	54	258
5	1385	22	994	38	626	55	235
6	1362	23	971	39	603	56	212
7	1339	24	948	40	580	57	189
8	1316	25	925	41	557	58	166
9	1293	26	902	42	534	59	143
10	1270	27	879	43	511	60	120
11	1247	28	856	44	488	61	97
12	1224	29	833	45	465	62	74
13	1201	30	810	46	442	63	51
14	1178	31	787	47	419	64	28
15	1155	32	764	48	396	65	5
16	1132			49	373		

CABINET DIMENSIONS: 19.25" W X 21.25" H X 4" D

EGRESS MARKING SYSTEMS LLC
2285 RESERVOIR AVENUE
TRUMBULL, CT 06611-4743

PHONE: 203.610.6240
FAX: 203.610.6647
EMAIL: SALES@EGRESSMARKING.COM

The E-Lume-A-Path™ Lighting System is manufactured in the USA under US Patents 6,896,388 and 6,788,000



FLATLITE® Specifications

FLATLITE® lamp is extremely durable and impervious to breakage due to blunt force impacts. There are no filaments to break and the material can be bent and twisted to make 90-degree turns and corners as shown in this data sheet and referred to in the installation instructions.

FLATLITE® lamp is fabricated in many shapes and lengths. The E-Lume-A-Path System uses FLATLITE® 1/4" strip lamp for low level path marking and uses FLATLITE® panel lamps for low level EXIT signs.

FLATLITE® is a UL Recognized Component under the UL48 Standard for Electric Signs. It is treated as a light bulb that requires a fixture for protection from cutting or penetration from a sharp object.

FLATLITE® has been tested to the ASTM D1929-96 and ASTM D2843 Standards for Ignition Properties and Smoke Density, in addition to the Cleveland Open Cup and Pensky Martens Closed Cup Flashpoint analysis. FLATLITE® has also been analyzed for the complete Toxicity Characteristic Leachate Procedure (volatiles and semivolatiles) and is RoHS compliant, ensuring its safety for landfill disposal.

FLATLITE® Lamp Physical Characteristics

Lamps can be cut to length from coils on site or prepared ahead of time. On-site fabrication requires no more than scissors and electrical tape for each connection. The overall lamp width is 0.50 inches consisting of 0.25" width FLATLITE® and 0.125 over-laminate edge on both sides as shown below. FLATLITE illuminates a blue/green color on one side of the lamp, which is the off-white color side when off. The unlit side is aluminum foil with a clear plastic layer over it and is imprinted with the FLATLITE® name and lot number at intervals of 12-18 inches.

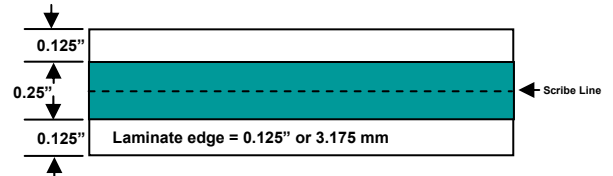

The following precautions should be taken when installing FLATLITE® lamp:

- a) Always disconnect lamp from any power supply before installing or modifying.
- b) Always make cuts in the lamp perpendicular to the lamp's edge.
- c) Always terminate the lamp ends by either installing connectors and insulating with electrical tape, or insulating ends without connectors with electrical tape.
- d) Never bend the lamp along the center scribe line.
- e) Do not break through the outer clear covering of the lamp (except when trimming the lamp). This will expose the lamp inside to the environment. This could be a shock hazard and damage the lamp.
- f) When folding the lamp, follow the instructions in the preceding diagram. Allow loose bends. Do not crimp the material firmly.
- g) Do not carry or pull the lamp by the lead wires. This could damage the connection and cause its failure to light.

Corners:

FLATLITE® lamp can be folded when 90 degree or other angle corners need to be made (around doors and at stair raisers), the lamp is folded as follows so that the lit side stays facing out.

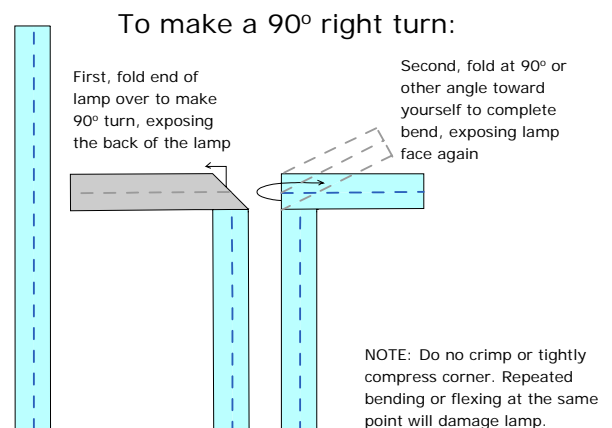

FLATLITE® is a registered trademark of E-Lite Technologies, Inc. FLATLITE® lamp is manufactured in the USA under US Patents: 5,019,748; 5,045,755; 6,833,669

FIXTURE SYSTEM

The ELAP system utilizes traditional surface mounted wiring raceway components and specially formulated, clear raceway, called ClearTrak, to create a fixture for the FLATLITE® lamp.

The ClearTrak is a single piece, low profile surface mounted clear lamp fixture with a hinged top to hold the lamp. This lamp fixture also comes in an opaque, off-white color and is called WhiteTrak for use in transitioning around non-exit doors or other architectural features.

- Surface mounted, clear and opaque PVC raceway
- V0 flammability rating per UL 94
- Installed in combination with Wiremold 400 series raceway blank end fittings and junction boxes and Low Level Exit Sign

ClearTrak AND WhiteTrak LAMP FIXTURES

The ClearTrak and WhiteTrak lamp fixtures are supplied in 8 foot lengths which include 2-sided adhesive tape already mounted to one side and a peel-off cover on the other. The tape is used to aid in alignment and installation although mechanical means such as screws must be used. Angles and corners are made by miter cutting and butting the track together as described in the E-Lume-A-Path installation manual. Its low profile allows ClearTrak to be recessed between moldings or installed directly on the wall, molding or door frame surface.

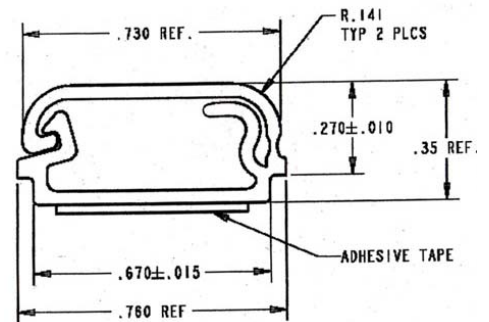

LOW LEVEL EXIT SIGN

The low level EXIT sign is an optional component of the E-Lume-A-Path system. This EXIT sign is only to be used with the E-Lume-A-Path system and should never be connected to standard building power circuits. When installed as part of the E-Lume-A-Path System, it meets the requirements of NFPA Life Safety Code 101, Section 7.10.1.6. Floor Proximity Exit Signs.

The ELAP Exit Sign is provided as a kit which requires a choice of one of two mounting base options. One option is a solid rear panel that is generally used within a run of lamp and the other includes an integrated junction box, which fits a standard round recessed box. This base is generally used when the Exit Sign serves as a distribution point for a run of lamp. The mounting bases are adhered directly to the wall surface with screws or by using an optional Quick Mount bracket. The Solid (ELAP-LLE-13-871) and Junction Box (ELAP-LLE-13-852) Bases are shown here separately and with the optional Quick Mount Bracket (ELAP-LLE-13-855) attached.

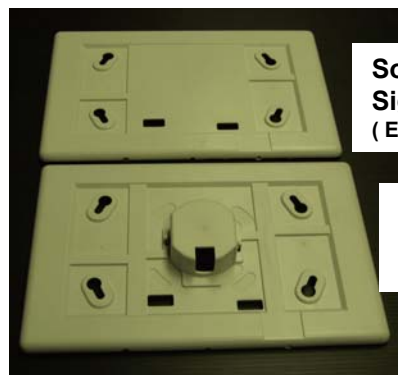

Solid Exit Sign Base
(ELAP-LLE-13-871)

Junction Box Exit Sign Base
(ELAP-LLE-13-852)

Quick Mount Bracket
(ELAP-LLE-13-855)



ELAP EXIT Sign Dimensions

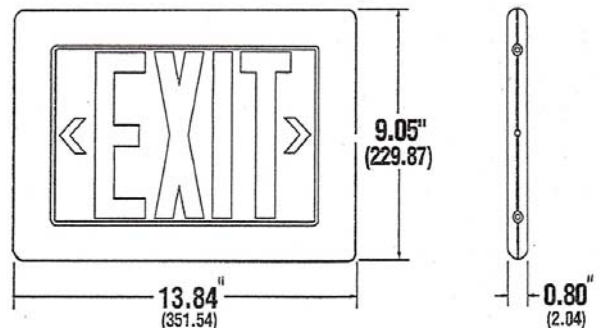

FLATLITE CONNECTOR

Connecting FLATLITE lamp to standard wiring simply requires piercing through and contacting the aluminum layer of the lamp with a connection on either side of the lamp scribe line. This connector has been specially engineered to make the connection using only standard pliers. Simply cutting a square end on the lamp with scissors is all that is required. Part # FL-0025-TLCONN.

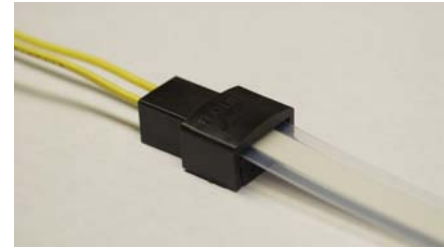

DIRECTIONAL ARROWS

Directional arrows are printed a clear decal that can be added to the inside of the ClearTrak lens to provide a means of pointing the way toward the exits. The arrows can be applied in a single direction or put back to back to signify that both directions lead to an exit. These arrows are meant to supplement existing exit signage and should not be a substitute for low level exit signage. Part # ELAP-ARROW.



FIXTURE ACCESSORIES – PROVIDED BY 3RD PARTIES

To properly transition from distribution wiring to the FLATLITE connection, a UL listed and approved junction box must be used. The WireMold Shallow Device Box # 2348S/51 has been approved for use with the ELAP fixtures. Also, the WireMold Blank End Fitting # 410B has been approved to properly terminate a run of lamp.

410B/810B/2310B* **Blank End Fitting** – For closing end of 400, 800, or 2300 Raceway.

Cat No.	A	B
410B	13/16" [20.6mm]	1/2" [12.7mm]
810B	1 1/4" [32mm]	1/2" [12.7mm]
2310B	2 1/4" [57mm]	1" [25mm]

2348S/51* **Shallow Device Box** – For mounting shallow modular wall jacks, switches, and receptacles.
♦ Accepts NEMA Faceplates

Cat #	Gang(s)	A	B	C
2348S/51	1	4 3/4" [121mm]	3" [76mm]	7/8" [22mm]

THE LITEGUIDE™ SYSTEM FROM ASSA ABLOY

The ASSA ABLOY Group companies include the world's leading manufacturers of Door Security Solutions including doors, frames, locks and architectural hardware. Their 35 worldwide brands include some of North America's most trusted names including Ceco, Corbin Russwin, Curries, Fleming, HES, McKinney Sargent and Yale.

Many of these visionary companies have incorporated FLATLITE lamp into a family of products called LiteGuide™, with illuminated exit devices, mortise locks, door mounted exit signs and frames. These products can be provided as stand alone components through the ASSA ABLOY Door Security Solutions group and their authorized distributors.

LiteGuide products have been engineered to easily integrate with the E-Lume-A-Path system with junction boxes located in the door frames and knockout locations that accept the ClearTrak fixture. In addition, they offer a frame option that includes bypass wiring from one side to the next to allow easy transitions across doorways that are not in the emergency egress path. For more information about the LiteGuide system please see www.liteguide.com or contact your EMS representative.



The E-Lume-A-Path System is classified as a Class 1 Power Limited System per NFPA 70, *National Electric Code* (NEC) Section 725. Two conductor, 18 AWG stranded wire is recommended for lamp distribution. (Note: Select distribution wiring in accordance with local electrical codes.) Because the operating voltage is a nominal 200VAC with low ampacity, there is no practical limitation on the maximum distance between the controller and lamp connection. A line distance of 500 continuous feet would be acceptable.

WIRING MODES – STANDARD AND REDUNDANT

FLATLITE® strip lamps are always wired in a parallel arrangement and never in series. For E-Lume-A-Path installations, they can be wired using a Standard or Redundant Wiring Mode. As AC devices, there is no preferred polarity for connecting FLATLITE lamps to the Output Channel terminals.

Standard Wiring Mode

Power to the FLATLITE lamp is only required at one end of each individual strip of lamp material. Multiple lamp strips and EXIT signs can be connected in parallel or end-to-end, daisy-chained configuration, as shown in the figures below, up to the maximum length/area supported by the System. In the Standard Wiring Mode, if a section of a FLATLITE lamp strip is somehow damaged or severed in the middle of the run, the section of lamp strip still connected to the Distribution Wiring will stay lit unless it is shorted.

Redundant Wiring Mode

FLATLITE lamps can also be wired in a closed loop manner similar to Class A Fire Alarm wiring. While maintaining polarity, a single pair of conductors are paralleled to feed both ends of each strip of lamp, thus powering it from both ends. Additional wiring is indicated by the dashed lines shown in the figures below.

For systems wired using the Redundant Wiring Mode, the FLATLITE lamp(s) will maintain illumination along the entire length, in the case of a single point being damaged or severed, unless it is shorted.

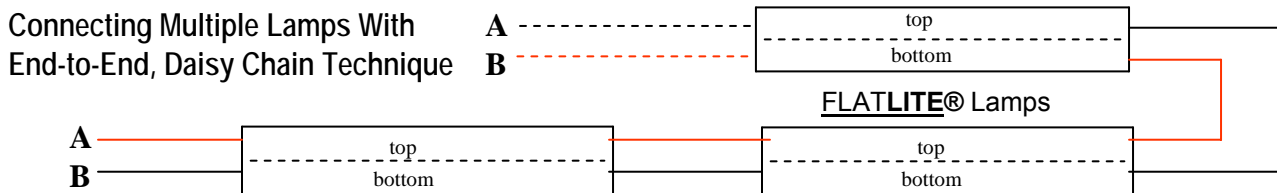
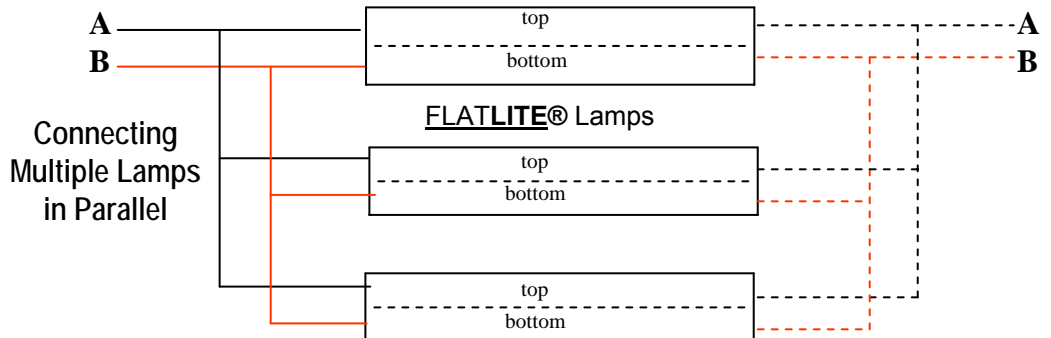
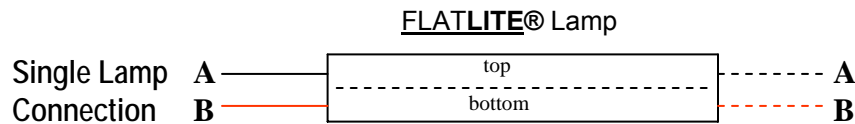
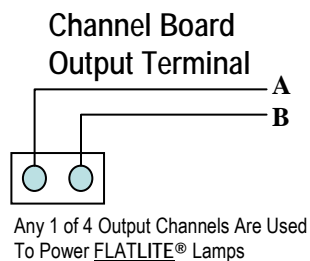
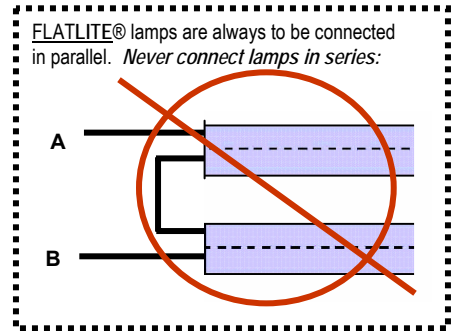

E-LUME-A-PATH SYSTEM DESIGN GUIDELINES

The E-Lume-A-Path system is an active, electric based Floor Proximity Path Marking System. As such, it is an engineered system and must be applied to a specific building project. The installation of an E-Lume-A-Path system presumes that the system has been designed with complete layout and wiring drawings for the installer to follow. Where local code requires the use of such systems, the required location of the path lighting may be predetermined by the code. Where the system is being installed as an additional safety measure without mandate there may be more flexibility in the location of the lighting.

As a general rule, Floor Proximity Path Marking should be installed in main egress corridors which, in theory, links the currently required exit signs out through to the exit door. For multi-floor buildings, the stairwell entrance doors, along the stair stringer and around mezzanine landings should be considered high priorities and the minimum installation. The perimeter of large atrium, convention hall or foyer locations are not high priority areas and the egress path can begin with the doorways exiting the area.

The presence of local code may also determine whether the local Authority Having Jurisdiction must review and approve the system drawings before installation takes place. It is highly recommended that these officials, who may include Fire Marshals and Building Inspectors, be consulted on any project involving the E-Lume-A-Path system regardless of code.

SCOPE OF WORK FOR INSTALLATIONS AND REQUIRED LICENCES

The basic work scope for installing the E-Lume-A-Path system is very straightforward and is predominantly electrically based. One skill set involves cutting the plastic track with a miter saw, installing screws and anchors, depending on the type of surface. Assembling Exit Signs, terminating lamp and running the lamp in the track require relatively low skill when compared to routing distribution wiring. The system set up and installation requires the basic skills of an alarm or low voltage system technician. Connecting the main building power requires the skills of a qualified electrician.

Each state or local jurisdiction have their own licensing practices and categories. Even though the system is distributing 200 VAC, it is classified by the National Electric Code as a Class 1, Power Limited System with a maximum amperage available of 2 amps. Because of the amperage rating, many jurisdictions only require a low voltage or low power license to install the system up to the point of connecting building power. In other states a full journeyman electrician license will be required for even the work scope that requires the most basic skills.

E-LUME-A-PATH SYSTEM PRICING

Component pricing for the E-Lume-A-Path system does not include engineering, design, installation or startup services. The installing contractor should provide these services as part of a complete installation.

Additional materials such as junction boxes, end caps, screws, anchors, power and distribution wiring are also required to complete the system and will be included by the contractor.

E-Lume-A-Path System Component	Catalog #	Purchase Unit
E-Lume-A-Path Controller - EP-1500 ** <small>** Batteries not included. Requires (2) 18ah Powersonic batteries for 4 hours of backup</small>	EP1500	each
Power-Sonic 18 amp-hour batteries, Model # PS-12180NB	ELAP-PS-12180NB	Pair
FLATLITE Lamp, 0.25" Lighted width, Blue/Green	DFL-0025-G	Linear Foot
ELAP ClearTrak - 8' Clear Hinged low profile	ELAP-EXT-LP-8	8 ft section
ELAP WhiteTrak - 8' Off white Hinged low profile	ELAP-EXT-LP-8-O	8 ft section
FLATLITE Connector Assembly	FL-0025-TLCONN	Each
ELAP Exit Sign Kit - Includes face, lamp & accessories Requires one of the following Mounting Bases	ELAP-LLE-Kit	Each
ELAP Exit Sign Mounting Base - Solid Panel	ELAP-LLE-13-871	each
ELAP Exit Sign Mounting Base - w/ Integral Junction Box	ELAP-LLE-13-852	each
Exit Sign Quick Mount Bracket (Optional)	ELAP-LLE-13-855	each
ELAP Track- Directional Arrows for ClearTrak (Optional)	ELAP-EXT-Arrow	Roll of 50

EGRESS MARKING SYSTEMS LLC
2285 RESERVOIR AVENUE
TRUMBULL, CT 06611-4743

PHONE: 203.610.6240
FAX: 203.610.6647
EMAIL: SALES@EGRESSMARKING.COM

The E-Lume-A-Path™ Lighting System is manufactured in the USA under US Patents 6,896,388 and 6,788,000

